

LUBRICATE ALL SEALS WITH CLEAN HYDRAULIC OIL PRIOR TO ASSEMBLY. DO NOT USE SILICONE BASED LUBRICANTS.

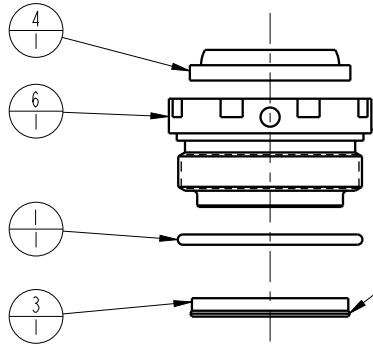

TIGHTEN TO 75 Nm TORQUE (55 FT-LBS)
 USE VEKTEK TORQUE TOOL
 NEW STYLE TORQUE TOOL AT200103, 10 POINTED TOOL (CIRCA 2018)
 OLD STYLE TORQUE TOOL AT200151, 2 POINTED SPANNER HOLE TOOL

INSTALL WITH LIPS DOWN

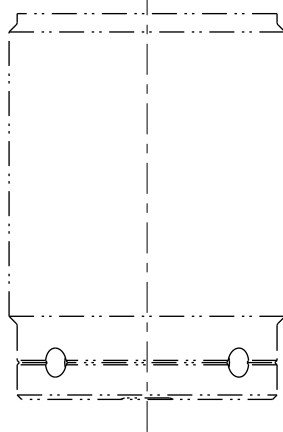
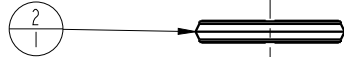
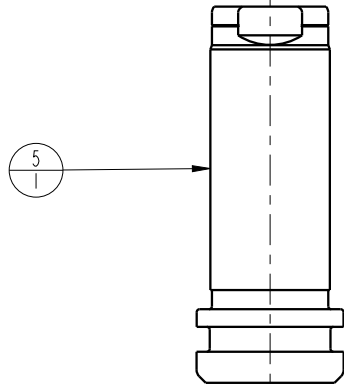

BODY,
 NOT A REPLACEMENT PART

N/A	N/A	6V200209	KIT, SEAL, FKM	N/A	NOTED
N/A	N/A	46000032	KIT, SEAL, STANDARD	NOTED	N/A
6	1	82031002	GLAND,CYL, 3900 & 17.8 KN		
5	1	48011001	PISTON,CYL,17.8 kN,25.5 STRK		
4	1	39012008	WIPER,SNAP-IN, (13/16)	X	X
3	1	39011045	SEAL, LL, (13/16 X 1/8 X 1/8 X 1-1/16)	X	39012005
2	1	39010017	SEAL,CROWN,13/16x1x5/32	X	39V10017
1	1	39001011	O-RING, (-024)	X	39012013
No.	QTY	PART No.	DESCRIPTION	Standard Seal Kit	FKM Seal Kit

PARTS LIST



VEKTEK, INC.
 1334 E. SIXTH AVE. P.O. BOX 625
 EMPORIA, KS. 66801 U.S.A.

ASSEMBLIES AFFECTED
 42002000

PARTS LIST, ASSY,CYL,TB,17.8KN,25.5 STRK,DA

SIZE A
MPL2049

REV J

J	4249	RELEASE	JDW	08/09/20
REV	IN ACCORDANCE WITH ECN	EFFECTIVE DATE	REVISED BY	DATE
DRW BY:	BUSH	DRAWING STATUS: Released		
DATE:	12/14/94	PRODUCTION APPROVED FOR RELEASED STATUS ONLY		

FORM FEG035_PL_ASIZE, REV. B

SHEET 1 OF 1